

# Low temperature merchandiser

## Tulip

**TF 17/33**

**TS 17/33**

Open display freezer with curved definition design and a small footprint. Excellent product display in the fully glazed product compartment. TS models are equipped with chiller/freezer switch.

### Options and accessories

- Sliding glass lid.
- Partition insert.



TULIP 33



TULIP 17



**CUSTOMER'S NO 1 CHOICE**

# Tulip TF 17/33 TS 17/33

## Some features and benefits

- All products fully displayed from top and through glazed sides.
- Lightbox for product illumination and brand promotion.
- Footprint just 0,66 m<sup>2</sup> for Tulip 17 – ideal to place in the cash register zone.
- Wheels are standard and make the unit easy to place, easy to move around.
- Suitable for branding or profiling in different colour combinations.

## Cooling

- Forced air cooling system.
- Refrigerant R404a, CFC free.
- Fully automatic hot gas defrost and water evaporation.



## Lightbox Dimensions of transparency

Model	Length x height, mm
TC 17	470 x 185 mm
TC 33	620 x 185 mm

4 mm at each side, 5 mm at top and 9 mm at bottom are covered by the lightbox frame.

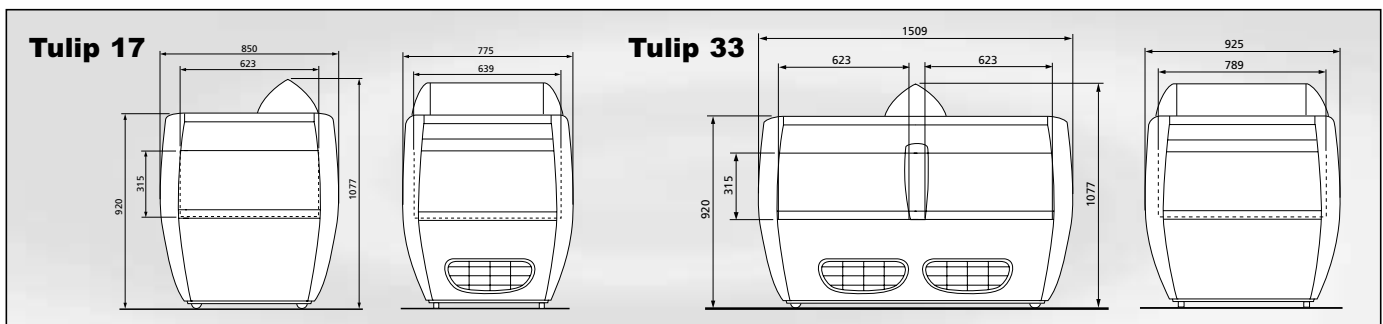

## Technical data

Models	Storage temperature, °C		Display area, m <sup>2</sup>	Net volume dm <sup>3</sup>	Total weight incl packing, kg	Loading capacity		Electric supply**
	chiller	freezer				Cont 40 ft	Truck 13,6 m	
TF 17		-29/-28	0,74	125	114	60	90	230V* 50Hz 10A Ⓞ
TF 33		-29/-28	1,90	310	212	30	34	
TS 17	-1/0	-29/-28	0,74	125	114	60	90	
TS 33	-1/0	-29/-28	1,90	310	212	30	34	

\* Voltage range 220–240V~

\*\* 230V 60Hz also available

