

# Low temperature merchandiser

## Crystal COI 17/33/34 COG 17/33/34

Superb merchandisers for ice cream and frozen food where three sides, or all sides, of the product compartment are fully glazed. COG models are equipped with chiller/freezer switch.

### Options and accessories

- Partition inserts, perspex.
- Product dividers, wire.
- Corner taps for attachment of display supports or the like.
- Low heat emission lightbox or vertical lightbox.
- Day cover.
- Night cover.



CRYSTAL CO 33, CO 34



CRYSTAL CO 17



CUSTOMER'S NO 1 CHOICE

# Crystal COI 17/33/34 COG 17/33/34

## Some features and benefits

- All products fully displayed from top and through glazed sides.
- Slim profiles with integrated lighting for excellent product visibility.
- Suitable for branding or profiling in different colour combinations.
- Wheels and thermometer are standard.

## Cooling

- Forced air circulation.
- Refrigerant R404a, CFC free.
- Fully automatic hot gas defrost and water evaporation.
- Reversible air flow during defrost.



**Lightbox** Dimensions of transparency

Model	Vertical model* Length x height, mm	Low-E model** Length x height, mm
CO 17	774 x 164	775 x 210
CO 33	840 x 164	775 x 210
CO 34	1598 x 164	1598 x 210

\* 4 mm at each side and 5 mm at top and bottom are covered by the lightbox frame.  
\*\* 3 mm at each side and 7 mm at top and bottom are covered by the lightbox frame.

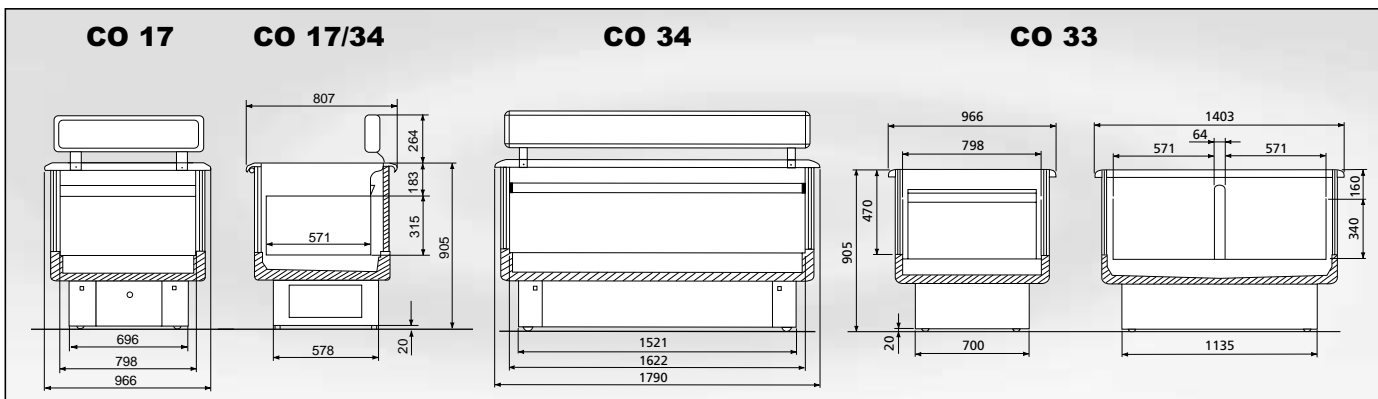

## Technical data

Models	Storage temperature, °C		Display area, m <sup>2</sup>	Net volume dm <sup>3</sup>	Total weight incl packing, kg	Loading capacity		Electric supply**
	chiller	freezer				Cont 40 ft	Truck 13,6 m	
COI 17	-	-29/-28	1,1	144	125	56	64	230V* 50Hz 10A ⚡
COI 33	-	-29/-28	2,2	310	219	32	36	
COI 34	-	-29/-28	1,8	292	204	26	30	
COG 17	-1/0	-29/-28	1,1	144	125	56	64	
COG 33	-1/0	-29/-28	2,2	310	219	32	36	
COG 34	-1/0	-29/-28	1,8	292	204	26	30	

\* Voltage range 220–240V~

\*\* 115V 60Hz and 230V 60Hz also available

